

PRECISION TURNTABLE

MODEL 20

MADE IN ENGLAND

INSTRUCTIONS

SME

SME

SME is an iconic brand founded in 1946 by audio legend Alastair Robertson-Aikman in West Sussex, England. Today SME is recognised as makers of the finest precision turntables and tonearms in the world. Entirely made in-house with state of the art manufacturing processes, complemented by traditional craftsmanship methods.

SME audio has evolved from 75 years of engineering excellence, innovation and perfection delivering precise and pure audio reproduction.

Audio Perfection

SME

MODEL 20
PRECISION TURNTABLE

INSTRUCTIONS

This is no ordinary turntable.
These instructions cover unpacking, set up, specifications and operation.
Please read carefully.



Warning! Important Safety Instructions

CAUTION: RISK OF ELECTRIC SHOCK DO NOT REMOVE POWER UNIT COVERS.

CAUTION: TO REDUCE THE RISK OF ELECTRIC SHOCK, DO NOT REMOVE THE POWER UNIT OR SPEED CONTROL UNIT COVER. THERE ARE NO USER SERVICEABLE PARTS INSIDE. REFER ALL SERVICING TO QUALIFIED PERSONNEL.

- Please read this manual carefully and keep it in a safe place for future reference.
- The vent slots in the Speed Control Unit are for necessary ventilation. To ensure reliable operation of this apparatus and to protect from overheating these vents must never be blocked or covered.
- Do not place a water containing vessel on this apparatus, as this can result in a risk of fire or electric shock. Do not expose this apparatus to rain or place it near water.
- If this apparatus accidentally gets wet, unplug it and contact an authorised dealer immediately.
- You can clean this apparatus with a damp cloth when necessary, but be sure to unplug the apparatus first. To cut off the power source, unplug the apparatus from the AC wall outlet.
- Do not overload AC wall outlets, power cables or adaptors beyond their capacity as this can result in fire or electric shock.
- Power cables should be routed so that they are not likely to be walked on or pinched by items placed upon or against them, paying particular attention to cables at the plug end, adaptors and the point they exit from the appliance.
- Before connecting the AC power cable to the Power Unit, make sure the voltage of the Power Unit, as marked on the identification label at the rear, corresponds to the local electricity supply.
- Never insert anything metallic into the open parts of this apparatus.
- Only a qualified technician should remove the Power Unit or Speed Control Unit cover.
- Be sure to hold the plug, not the power cable, when disconnecting this apparatus from an electric socket.
- Locate this apparatus near an easily accessible AC outlet.
- If this apparatus does not operate normally, in particular if there are any unusual sounds or smells, unplug it immediately and consult an authorised dealer.
- Unplug this apparatus from the AC outlet before any service.

IMPORTANT NOTICE:

The power cable on this equipment when supplied for use in the UK, is fitted with a moulded plug incorporating a fuse. The value of the fuse is indicated on the pin face of the plug and if it required replacing a fuse approved to BSI 1362 of the same rating must be used. Never use the plug with the fuse cover omitted if the cover is detachable. If the plug fitted is not suitable for the power points in your room or if the power cable is not long enough to reach the power point, you should obtain a suitable safety approved extension lead or consult your dealer for assistance.

IMPORTANT:

The wires in the power cable are coloured in accordance with the following code: **BLUE NEUTRAL, BROWN LIVE**. As these colours may not correspond to the coloured markings identifying the terminals in your plug, proceed as follows: The wire coloured BLUE must be connected to the terminal marked with the letter N or coloured BLUE or BLACK. The wire coloured BROWN must be connected to the terminal marked with the letter L or coloured BROWN or RED.

WARNING:

DO NOT CONNECT EITHER WIRE TO THE EARTH TERMINAL, WHICH IS MARKED WITH THE LETTER (E) OR BY THE EARTH SYMBOL OR COLOURED GREEN OR GREEN/YELLOW.



WEEE SYMBOL INFORMATION

Correct Disposal of This Product (Waste Electrical & Electronic Equipment)

(Applicable to the European Union and other European countries with separate collection system).

The marking shown on this product or its literature, indicates that it should not be disposed with other household wastes at the end of its working life. To prevent possible damage to the environment or human health from uncontrolled waste disposal, please separate this from other types of wastes and recycle it responsibly to promote the sustainable re-use of material resources.

Household users should contact either the retailer where they purchased this product or their local government office, for more detailed information of where and how they can take this item for environmentally safe recycling.

Business users should contact their supplier and check the terms and conditions of the purchase contract. This product should not be mixed with other commercial wastes for disposal.

1. CONTENTS

Page	
6	Introduction
7	Dimensions & Weights
7	Drive System
7	Speed Range
8	Packing List
9	Parts Identification - Turntable
11	Unpacking
13	Setting Up - Turntable
15	Setting Up - Tonearm
16	Power Cable Connections
17	Operation - Turntable
18	Operation - Playing a Record
18	Operation - Tonearm
19	Maintenance
20	Transit Precautions
21	Guarantee
22	Appendix

2. INTRODUCTION

The SME Model 20 precision turntable is built to the same engineering standards and incorporates many of the design features originated for the Model 30. This splendid turntable offers total reliability and freedom from critical adjustments. The high mass construction and vibration free moving parts ensure wide-band sound of exceptional detail and resolution with a dynamic range.

3. DIMENSIONS & WEIGHTS

Turntable	mm (inch)
Width	440 (17.32)
Depth	350 (13.77)
Height (top of tonearm)	175 (6.88)
Speed Control Unit	
Width	150 (5.90)
Depth	295 (11.61)
Height	82 (3.46)
Power Unit	
Height	82 (3.46)
Width	188 (7.40)
Depth	242 (9.52)
Platter	325 (12.79)
Weight	
kg (lb)	
Turntable	26 (57.32)
Power Unit	4.04 (8.90)
Speed Control Unit	2.52 (5.55)
Shipping	36.37 (80.18)

4. DRIVE SYSTEM

The turntable is driven by a custom made bi-phase AC synchronous motor. The speed control unit uses a dedicated DSP engine to generate two independent pure mathematical sine waves which provide total control of frequency, phase relationship and amplitude. These in turn are matched (tuned) to the motor for accuracy to obtain the best possible performance. The output driver stage is a 2 channel, class AB Bi-polar design with low distortion and relay coupled directly to the motor. The entire design is implemented using high quality surface mount technology on a gold plated FR4 PCB.

5. SPEED RANGE

The speed range is $33\frac{1}{3}$ and 45rpm with independent memory settings via a switched encoder.

6. PACKING LIST

Qty	Description	✓
1	Model 20 Turntable Tonearm	<input type="checkbox"/>
1	Speed Control Unit	<input type="checkbox"/>
1	Power Unit – 100V <input type="checkbox"/> 115V <input type="checkbox"/> 230V <input type="checkbox"/>	<input type="checkbox"/>
1	Power Cable – UK <input type="checkbox"/> EU <input type="checkbox"/> USA <input type="checkbox"/>	<input type="checkbox"/>
1	LEMO Power Cables A&B	<input type="checkbox"/>
1	Drive Belt	<input type="checkbox"/>
1	Syringe of Bearing Oil	<input type="checkbox"/>
1	Platter	<input type="checkbox"/>
1	Stroboscopic Disc	<input type="checkbox"/>
1	Oil Filler Adaptor (fitted)	<input type="checkbox"/>
1	Oil Filler Box Spanner	<input type="checkbox"/>
1	Record Clamp	<input type="checkbox"/>
1	Record Spindle Washer	<input type="checkbox"/>
1	Suspension Height Setting Gauge	<input type="checkbox"/>
4	M3 x 12 Cap Screws (fitted)	<input type="checkbox"/>
1	2mm Hex Wrench	<input type="checkbox"/>
1	2.5mm Hex Wrench	<input type="checkbox"/>
1	4mm Hex Wrench	<input type="checkbox"/>
1	3mm Hex Handle Wrench	<input type="checkbox"/>
1	Tonearm Tool Kit	<input type="checkbox"/>
1	Guarantee Card	<input type="checkbox"/>
1	Tonearm Instruction Manual	<input type="checkbox"/>
1	Model 20 Instruction Manual	<input type="checkbox"/>

7. PARTS IDENTIFICATION - TURNTABLE

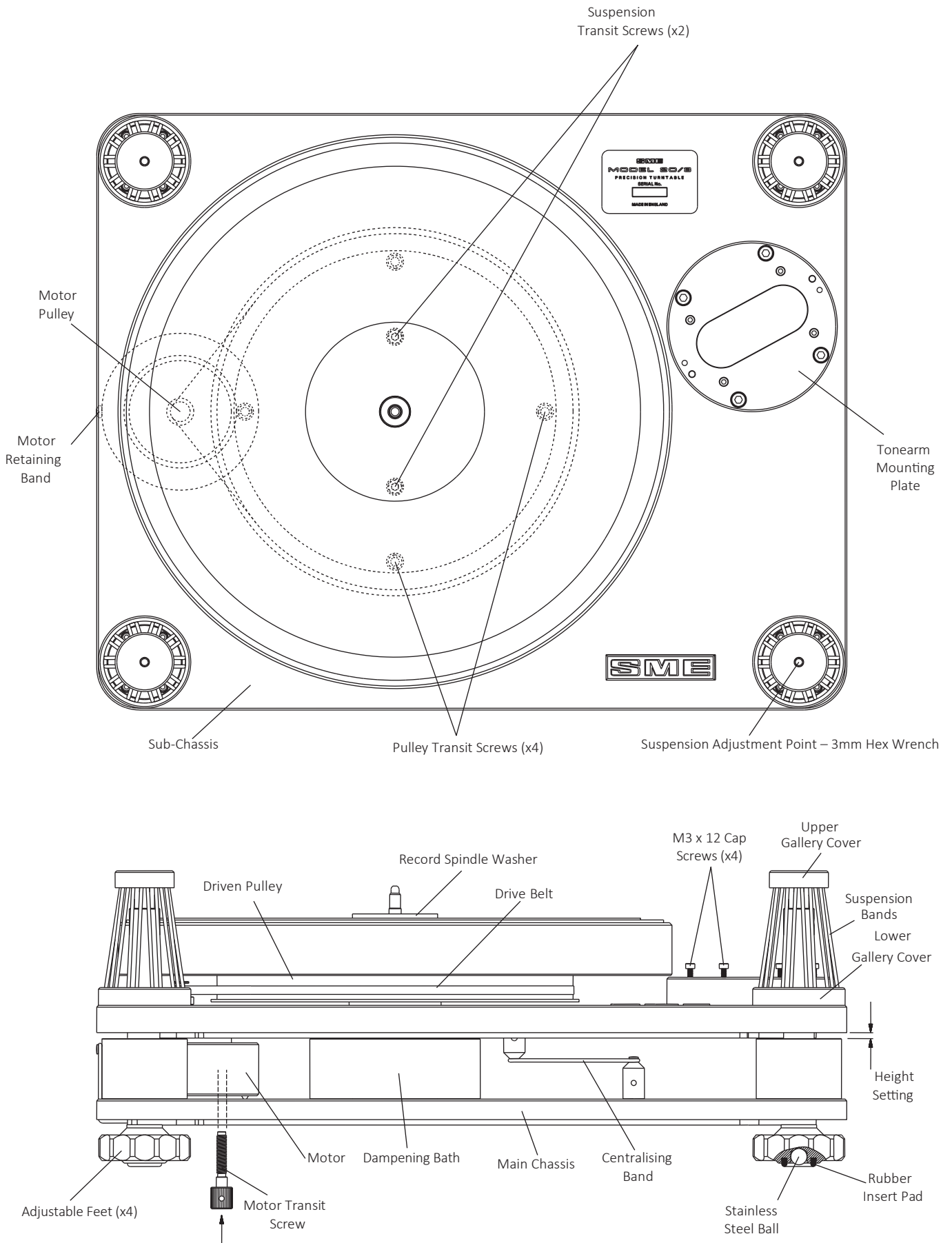

7. PARTS IDENTIFICATION - TURNTABLE (continued)



- | | | |
|-------------------------|-----------------|---------------------|
| 1. Speed Control Unit | 5. Platter | 9. Sub Chassis |
| 2. Power Button | 6. Record Clamp | 10. Main Chassis |
| 3. Rotary Speed Control | 7. Tonearm | 11. Adjustable Foot |
| 4. Air Vents | 8. Headshell | |

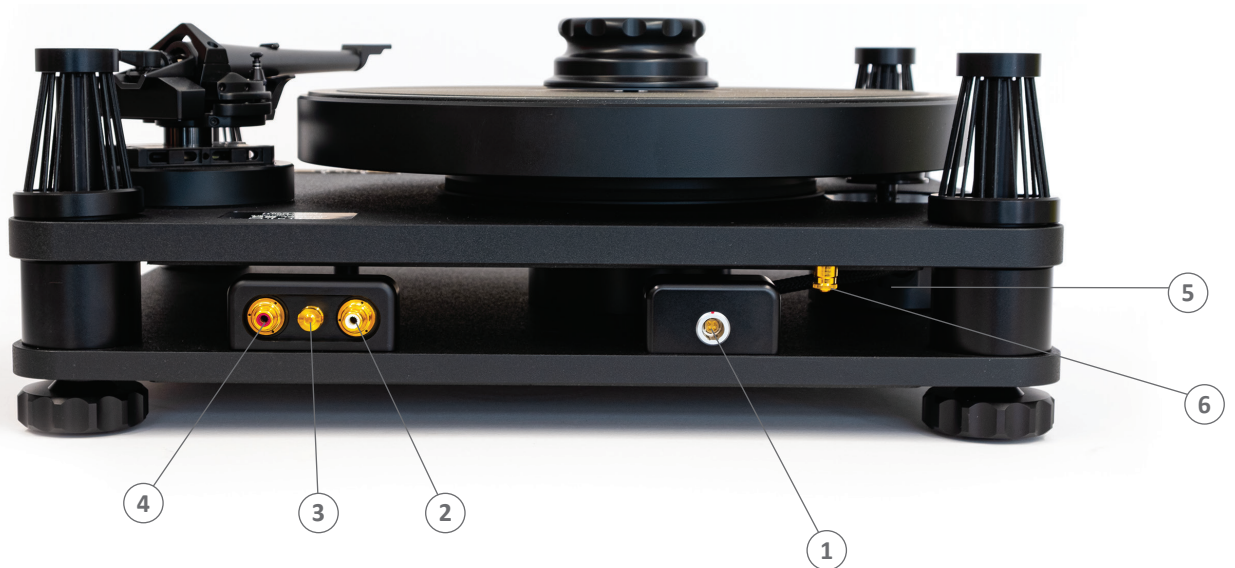

- | | | |
|-----------------------------|---------------------------|-----------------------|
| 1. Speed Control Unit Input | 3. Earth Post - Turntable | 5. Motor |
| 2. Left RCA Phono Output | 4. Right RCA Phono Output | 6. Earth Post - Motor |

8. UNPACKING

1. Unpack and check all items against the packing list on Page 8.
2. The turntable should be placed on a substantial table or strong audio stand, this should be in its final position for setting up, as movement after this procedure is best avoided.
3. The adjustable feet allow for two methods of interface with the mounting surface.
 - a) As received on rubber insert pads set into the underside of the feet.
 - b) Stainless steel balls also set into the underside of the feet.

WARNING:

Method (b) is not suitable for delicate surfaces as indentation damage may be caused.

4. If hard mounting the turntable on the stainless steel balls is preferred, proceed as follows:
 - a) Position the base so that one of the supporting feet overhangs the table by about 10cms, unscrew and remove that foot.
 - b) Remove the rubber pad from the foot by pushing out through the small hole on the upper side of the foot using the longer leg of the 2mm hex wrench.
 - c) Replace the supporting foot and repeat the procedure for the other three feet.
5. Lift the motor side of the turntable and remove the motor transit screw from the underside of the main chassis (immediately below the motor). Remove the two packing strips from beneath the motor and relocate the three motor base posts into the rubber compliance cups.
6. The turntable is packed with only a small quantity of oil in the bearing housing and this should now be filled. A metered charge (syringe) of bearing oil is provided.

8. UNPACKING (continued)

7. Remove the syringe from its packaging and insert the syringe tip into the oil filler adaptor, which will be found already fitted to near the spindle (as illustrated).
8. Slowly inject the complete quantity of oil into the bearing housing maintaining downward pressure throughout the operation to prevent leakage.

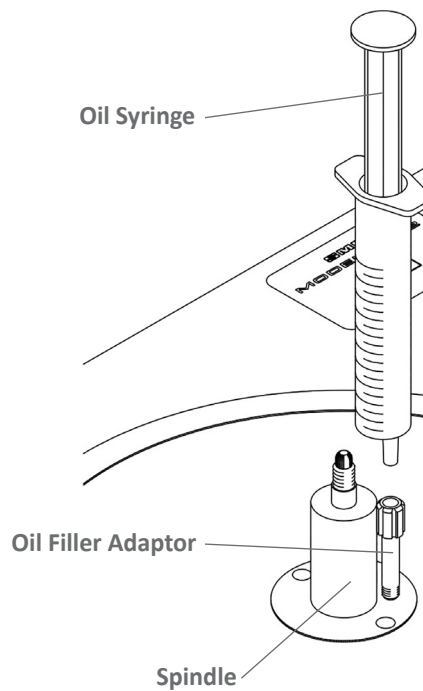

9. Remove the syringe and dispose of it responsibly.
10. Unscrew and remove the oil filler adaptor using the box spanner tool. Retain the adaptor for possible future use.

9. SETTING UP - TURNTABLE

1. Levelling

With the use of a spirit/bubble level ensure that the main chassis (lower chassis) is level in the lateral and longitudinal planes. The 4 feet are height adjustable and can be used to achieve a level chassis. When adjusting the feet it is recommended to slightly lift the chassis adjacent to the foot being adjusted. This aids ease of rotation of the foot and prevents the foot rubber pad binding.

2. Transit Locks

For transit the suspension is locked (secured) by two screws; these are accessible through holes in the driven pulley. The transit screws should be turned anti-clockwise with the supplied 4mm hex wrench and removed.

The main bearing is off-loaded by four pulley transit screws. These are captive and should be turned anti-clockwise with the 3mm ball-ended hex wrench until they stop. Ensure the wrench is fully engaged to avoid damage to the transit screw socket (see page 9, transit screws).

3. Drive Belt

Place the drive belt over the large driven pulley down as far as the pulley flange, ensuring that it is free from twists and stretch over the motor pulley. The pulleys will be out of alignment without the weight of the platter so rotation must not take place until the platter has been fitted.

4. Platter

Unpack the platter and place it carefully and squarely over the turntable spindle lowering it gently down until it rests on the driven pulley, having first ensured that both mating surfaces are clean. Rotate the platter slowly by hand to position the belt on the pulleys.

WARNING:

The unique damping material (isodamp) installed on the platter top surface has been diamond turned and scrolled for intimate contact with the record. Avoid handling the isodamp material and treat it like a vinyl record as it could be easily damaged.

5. Suspension

The sub-chassis suspension system is set to the operating height by way of inserting the 3mm hex wrench into the centre hole of each upper gallery cover and rotating clockwise to raise the sub-chassis. The operating height is correct when a 3mm clearance (gap) is achieved between the sub-chassis and column base as indicated on page 9. The 3mm clearance is measured by use of the height setting gauge. Anti-clockwise rotation of the 3mm hex wrench will lower the sub-chassis.

After setting the suspension height hold the sub-chassis fully down and then release it. Check and re-adjust as needed, noting that new suspension bands take a little while to settle down.

A single band arranged horizontally beneath the sub-chassis centralises the sub-chassis against the opposing pull of the drive belt.

9. SETTING UP - TURNTABLE (continued)

If it is desired to increase sub-chassis isolation because of unusually close proximity to the speakers the recommended suspension height clearance of 3mm can be reduced to 2mm. This lowers the spindle/bearing housing deeper into the dampening bath and subsequently increases the dampening action.

6. Power Unit & Speed Control Unit

The power unit is connected to the speed control unit and turntable by way of the connection cables (Section 16) with LEMO connectors. The cables cannot be confused as they carry a different number of pins which are purposely configured to observe both safety and miss-identification. The cables are identified as A and B.

1. Connection Cable A - Power Unit Output to Speed Control Unit Input
2. Connection Cable B - Speed Control Unit Output to Turntable Input

The AC mains power cable is connected to the power unit AC input. A push ON/OFF switch is located on the rear of the power supply unit.

IMPORTANT

The mains voltage setting is indicated on the rear panel of the power unit. Before fitting the mains power cable check carefully that this matches your mains voltage.

10. SETTING UP - TONEARM

The Model 20 is equipped with a mounting base for SME tonearms, Model 309, Series IV and Series V.

The tonearm manual provides installation, set up and operation information, including cartridge installation. Before fitting the tonearm ensure that the four socket cap screws holding the tonearm mounting plate to the sub-chassis are tight. The tonearm should now be secured to the mounting plate using the four M3x12mm cap screws. Rotate the output socket on the underside of the tonearm and connect to the audio cable extending from the main chassis.

The tonearm mounting plate is fitted with jacking screws to facilitate removal from the sub-chassis. They should be turned clockwise, alternately in small increments until the plate can be lifted off. The 2mm hex wrench is provided for this purpose.

11. POWER CABLE CONNECTIONS

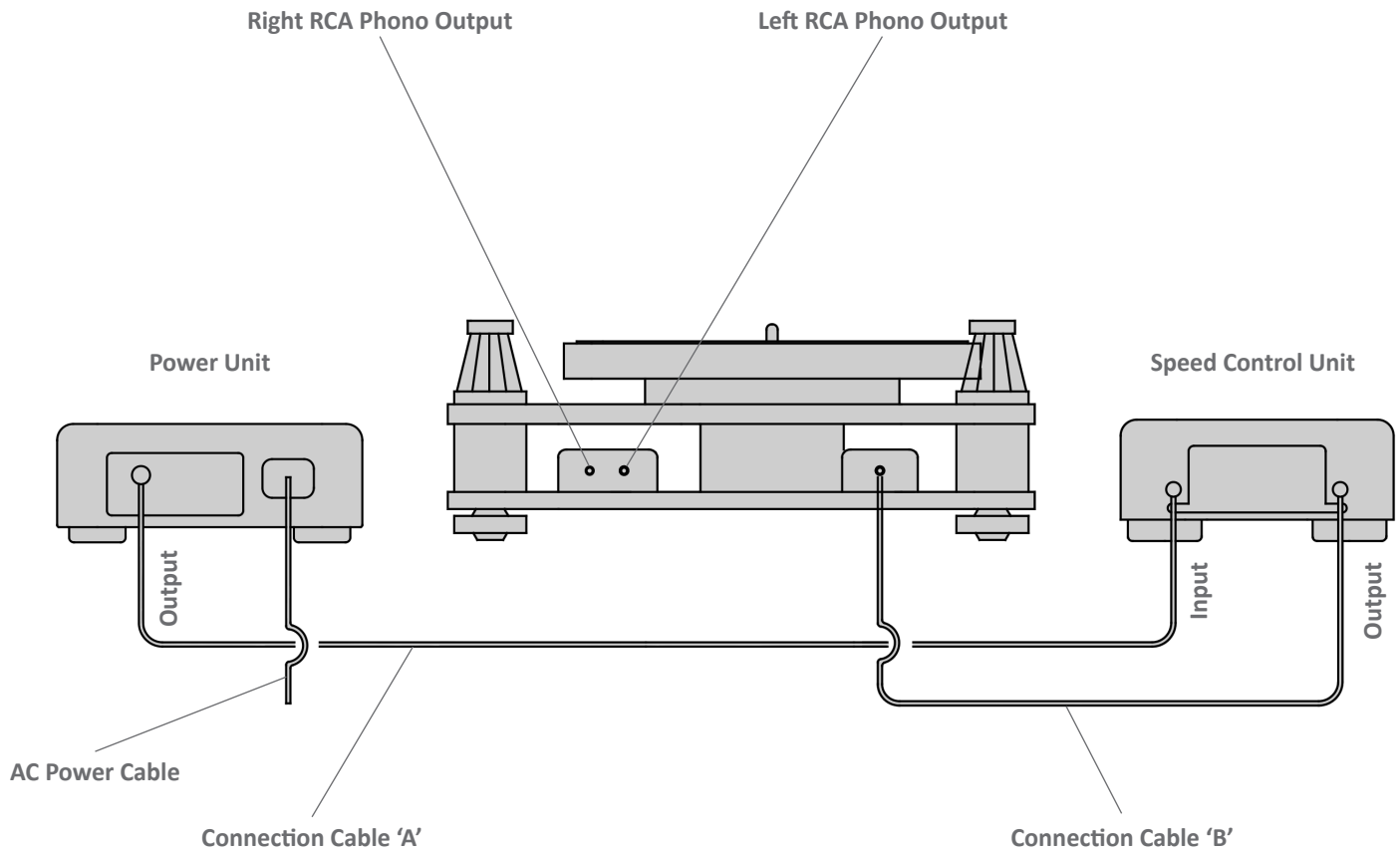

NOTE:

Mains power **must be off** when connecting and disconnecting Cables A and B.

12. OPERATION - TURNTABLE

The Model 20 precision turntable is partly run-in before leaving the factory but will benefit and improve after a few weeks of use. Do not worry if initially the bearing is not totally silent. A slight 'swish' barely audible at very close range in a silent room will quickly disappear after use of the turntable. If you should wish to check the speed settings and make your own adjustments the procedure is as follows:

1. **Mains Power:** the power ON/OFF button is located on the rear of the power unit. With power ON the last used speed indicator LED light will illuminate on the speed control unit fascia.
2. **Motor Power:** pressing the power button on the speed control unit fascia will start the motor. With power OFF and pressing the rotary button on the fascia the speed settings of $33\frac{1}{3}$ and 45rpm will cycle and be indicated by the speed LED. With the motor running, pressing the power button will stop the motor.
3. **Speed Testing:** the stroboscopic disc installed on the platter is used to check speeds of $33\frac{1}{3}$ and 45rpm. Use the strobe bands appropriate for your mains AC frequency. The disc should be viewed in a fluorescent or neon light. The appropriate band will synchronise and appear stationary when the speed is correct. Whilst forward and reverse band movement will indicate fast or slow running respectively. This is best observed with the cartridge fitted and the tonearm in the raised position and placed directly over the band being viewed as a reference point.
4. **Speed Adjustment:** with the motor running press and hold the rotary button for two seconds, the speed indicator LED will begin to flash. The motor is now in speed adjust mode and the speed can now be adjusted in conjunction with the stroboscopic disc. Turning the rotary button anti-clockwise will reduce speed and clockwise will increase speed. The method provides a microfine incremental adjustment. When the speed adjustment is completed depress and release the rotary button, the speed indicator LED light will stop flashing and become constant and the speed setting will be stored in the system memory for future use.
5. Repeat this process for the 45rpm speed range if required.

13. OPERATION - PLAYING A RECORD

Place the record spindle washer on the spindle followed by the record and clamp. The clamp should be screwed down clockwise enough to deflect the record flat into firm contact with the platter. With a fingertip, tap the record in three places equally over its surface and with a little practice it will soon become evident whether or not the record is touching the platter. If not, some further tightening of the clamp may be necessary.

14. OPERATION - TONEARM

1. With the control lever in the raised position move the tonearm out of the armrest and position the tonearm so that the stylus is over the selected record groove.
2. To lower the stylus onto the record move the control lever forward until it is just past top dead centre. This will set the lowering control in motion, at which point it will take over the movement of the lever, giving a smooth controlled descent.

Note: For the correct descent time the control must be operated exactly as above. The speed will be increased considerably if the lever is pushed down instead of being allowed to fall of its own accord.

3. To raise the stylus from the record slowly move the control lever back to its original position. When the tonearm is not in use it should always be returned to the armrest for safety.

15. MAINTENANCE

1. There are no critical adjustments or need for 'tweak' and only very little maintenance. Clean the drive belt occasionally by drawing it through a piece of soft tissue or linen moistened with lighter fuel. The same material may be used to clean the periphery of the motor and driven pulleys.
2. The suspension dampening bath is automatically sealed when the sub-chassis is locked down and does not require maintenance.
3. Replace the drive belt after 1000 hours use. A replacement belt is available from SME.
4. The life of the suspension bands will depend on climatic conditions. If eventually they should stretch beyond further adjustment, replacements are available from SME.
5. Changing the suspension bands is simple. Unscrew and remove the upper gallery cover from the top of the suspension column and lift off the lower gallery cover. Remove the old band(s) and attach the new band(s) onto the anchor studs. Replace the covers and re-check the suspension height with the height setting gauge.
6. The motor retaining and centralising bands will last indefinitely. However should they require replacing refer to the illustration on page 9.
7. There are no user-serviceable parts inside the speed control unit or power unit. A safety fuse is located below the mains socket, its replacement should only be undertaken by qualified service personnel.

16. TRANSIT PRECAUTIONS

The Model 20 can be safely transported,

SUBJECT ABSOLUTELY TO THE FOLLOWING PRECAUTIONS:

Short journeys by car: remove the platter, disengage the drive belt from the motor pulley, and replace the two packing strips beneath the motor and secure with the motor transit screw. Lock down the suspension. Screw down the four driven pulley transit screws not more than one turn, just enough to prevent the pulley rotating freely. The turntable itself is best placed on the floor of the car in front of the passenger seat. The platter and other items can be stowed elsewhere provided they are carefully protected. For all other transportation purposes the original packing case and materials must be used.

17. GUARANTEE

Your SME Model 20 turntable is guaranteed against faulty material and workmanship. The nominal period of the guarantee is 24 months but is liberally interpreted at SME's discretion subject to the following conditions being observed:

1. Any matter arising must in the first instance be reported to SME at the address below.
2. Do not return the turntable or any part thereof to SME unless requested to do so.
3. SME Limited will not accept liability for any items until they reach the factory safely.
4. Any parts found to be faulty will be replaced free of charge.
5. Return transport and insurance costs will be charged.
6. The guarantee expressly excludes:
 - (a) Damage by any cause.
 - (b) Contingent and third party liability.
 - (c) Personal injury.
7. No alteration or variation of the guarantee will be recognised by SME.
8. The guarantee is not transferable.

18. APPENDIX

We hope these instructions have made the installation of your Model 20 precision turntable straightforward. Care for it as befits its fine construction. Do not invert it. Do not apply oil or other lubricant except as directed. Do not attempt to take it to pieces or interfere with any of the screws except as directed in the instructions. To do so will invalidate the guarantee and may incur costly repairs. Keep your turntable clean by dusting it regularly with due regard for the safety of the cartridge and stylus. Finger marks may be removed from the finished surfaces with a linen handkerchief moistened with warm soapy water. Do not use any kind of spirit or solvent cleaner.

In the unlikely event of a problem concerning operation or service, always contact the supplying dealer or SME Limited stating the exact nature of the problem and the serial number which will be found on the rear of the main chassis.

EC DECLARATION OF CONFORMITY

The SME Model 20 Turntable has been manufactured to conform with the protection requirements of the EC Council Directive 89/336/EEC relating to EMC by application of the following standards:

BS EN 61000-6-3:2007+A1:2011 Emissions Standard.

BS EN 61000-6-1:2007 Immunity Standard and also the requirements of the EC low voltage directive relating to electrical safety by application of the following standard:

BS EN 62368-1:2014 International Safety Standard.

For the purposes of testing the SME Model 20 Turntable was used with the high quality interconnects supplied as standard equipment. Compliance with the above standards may only be made if the unit is installed as per this instruction manual and using the correct cables.

SME Limited · Mill Road · Steyning · West Sussex · BN44 3GY · England

SME

SME LIMITED • STEYNING • WEST SUSSEX • ENGLAND